

RECOMMENDED FPC/FPC DIMENSIONS
GENERAL TOLERANCE ±0.1

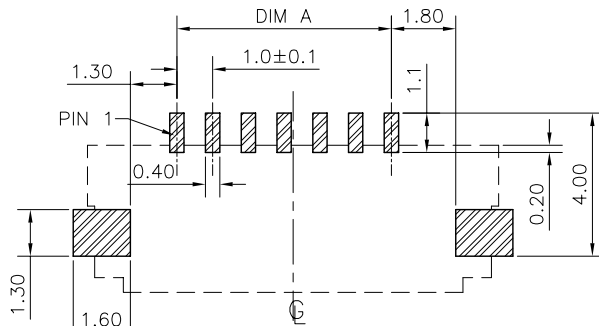
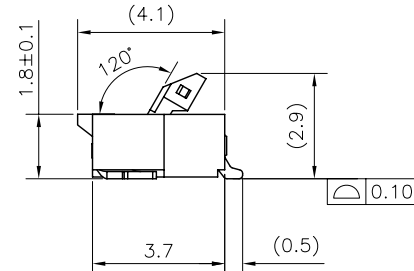
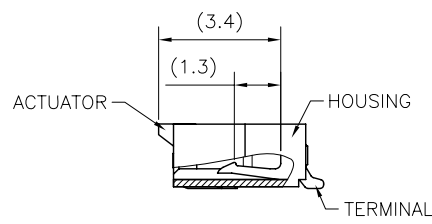

RECOMMENDED PCB LAYOUT
GENERAL TOLERANCE ±0.05

NOTES:

1. MATERIAL:
 - 1.1 HOUSING: THERMOPLASTIC, HIGH TEMP., UL94V-0.
 - 1.2 ACTUATOR: THERMOPLASTIC, HIGH TEMP., UL94V-0.
 - 1.3 CONTACT: COPPER ALLOY
 - 1.4 FITTING NAIL: COPPER ALLOY
2. FINISH:
 - 2.1 CONTACT:
 - 1:50u" MIN NICKEL UNDERPLATING OVERALL. GOLD FLASH PLATING.
 - N:50u"MIN NICKL UNDERPLATING OVERALL. 80u"MIN.MATT TIN
 - 2.2 FITTING NAIL:
 - 50u" MIN NICKEL UNDERPLATING OVERALL. 100u" MIN MATT TIN PLATING.
3. REFLOW SOLDER CAPABLE TO 260°C PER ACES SPEC.
4. SPEC. PLS. REFER TO PS-51503-xxxxx-xxx
5. PACKAGE PLS. REFER TO 51503-xxxxx-TRP
6. PART NUMBER
51503-XXX X X-XXX

NO OF CKT
PACKING
0:TAPE&REEL
4: TAPE & REEL WITH MYLAR
5: TUBE WITH MYLAR

HOUSING MATERIAL&COLOR	ACTUATOR MATERIAL&COLOR	HALOGEN FREE
001 HALOGEN FREE PLASTIC & NATURAL	HALOGEN FREE PLASTIC & BLACK	HF

PLATING
1: G/F (LEAD FREE)
N:MATTE TIN

CKT	DIM A	DIM B	DIM C	DIM D
18	17.00	18.57	20.20	22.50
26	25.00	26.57	28.20	30.50
30	29.00	30.57	32.20	34.50
32	31.00	32.57	34.20	36.50
34	33.00	34.57	36.20	38.50

一般公差
TOLERANCES
X. ±0.5 XX ±0.15
X ±0.25 XXX ±0.1
ANGLES ±2°

檢驗尺寸標示
SYMBOLS Ⓢ Ⓣ INDICATE CLASSIFICATION DIMENSION
Ⓢ MARK IS CRITICAL DIM.
Ⓣ MARK IS MAJOR DIM.

表面處理 (FINISH)

宏致電子股份有限公司
Aces Electronics Co.,Ltd.

品名 (TITLE) 1.0 PITCH EASY ON FPC Conn. H=1.8mm TYPE	製圖 (DR) 16/07/29 XUBIN
圖號 (DWG.NO) 51503-XXXXX-001	審核 (CHKD) BRAVE
比例 (SCALE) 3:1	核准 (APPD) FRANK
單位 (UNITS) mm	張數 (SHEET) 1 OF 1
圖號 (DWG.NO) 51503-XXXXX-001	SIZE A4
圖號 (DWG.NO) 51503-XXXXX-001	REV D